

AbmVTanh

AbmVCann

Multi-Sine Simulation Using Harmonic  
Balance in fREEDA

This project deals with the multi-sine simulation using harmonic balance (HB) simulator in fREEDA. A 149-tone multi-sine signal was designed based on a Fourier transformation (FT) scheme in order to approximate a digital modulated QPSK signal. This multi-sine signal was simulated using fREEDA HB simulator by passing through two nonlinear amplifier behavioral models, built in fREEDA as part of the work in this project. The quality of the multi-sine signal was evaluated with two figure-of-merits: power in the main channel and adjacent channel power ratio (ACPR). The results showed that the FT based multi-sine signal is a good way to approximate the digital modulated QPSK signal, and the fREEDA HB simulator is able to handle a large number of tones and provides accurate results.

## Introduction

Digital modulated signals are widely used in modern wireless communication systems in order to increase the spectral efficiency. Digital modulated signals are more complicated and random in nature, compared to analog modulated signal. The traditional two-tone representation is not enough to approximate amplitude fluctuation of the digital signals, therefore, incapable of charactering the channel distortions accurately by two-tone signals.

Multi-sine signals were designed in this work in order to approximate the digital excitations in ACPR measurement. Multi-sine is a set of simultaneously generated, usually equally-spaced sinewaves. Compared to digital signals, they are easier to generate and their peak-to-average (PAR) ratios are easier to characterize. Therefore, multi-sine is very useful in characterizing systems and circuits. Additionally, in behavioral modeling of a nonlinear system, the accuracy and predictive capability heavily depend on the stimulus data used to extract the parameters. In this sense, multi-sine is an important type of training data in nonlinear system behavioral modeling.

## Modeling of a QPSK Signal

A QPSK signal for transmitting was modeled in MatLab, as shown in the figure below.

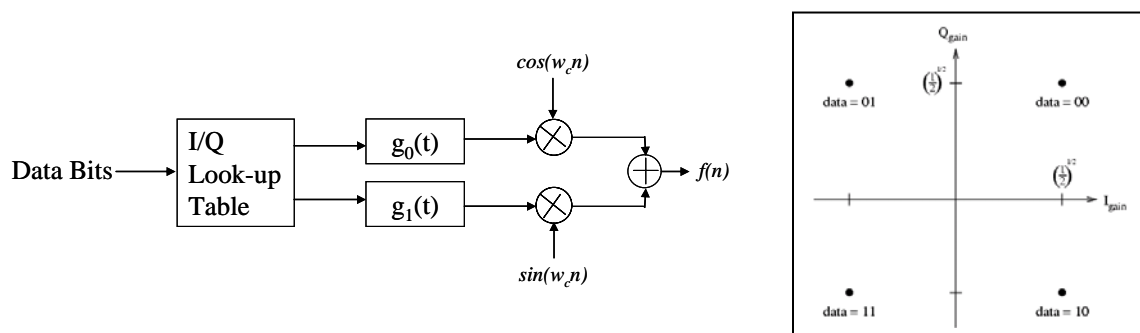

In a QPSK modulated system, the data bits are grouped in pairs. Each pair was mapped to one of four symbols, as shown in the constellation diagram. The information is carried by the different states in the constellation diagram. Each symbol is represented by a particular waveform and sent through the channel after pulse-shaping and modulating. The QPSK transmitter system uses both the sine and cosine at the carrier frequency to transmit two separate message signals, referred to as the in-phase and quadrature signals. This allows us to transmit twice the amount of signal information at the same carrier frequency as we could with a single oscillator, therefore, QPSK signals have a spectral efficiency of 2 bits/hertz.

Some design parameters for the modeled QPSK signal are summarized in the table. With this setting, there are total 10,000 points when doing a fast Fourier transformation on this realization of signal.

<b>Symbol Rate</b>	Rs	<b>100</b>	kHz
<b>Carrier Freq</b>	fc	<b>1</b>	MHz
<b>Sampling Freq</b>	fs	<b>10</b>	MHz
<b># of Symbols</b>	numSym	<b>100</b>	unitless

The time-domain waveform and power spectrum of the QPSK signal are shown below. The time domain waveform shows that a QPSK signal has a varied envelope. The deep notches are due to the transitions occurred through the zero point. At the beginning of the signal there is no waveform generated over a short period since there is a delay in the raised-cosine pulse-shaping filter.

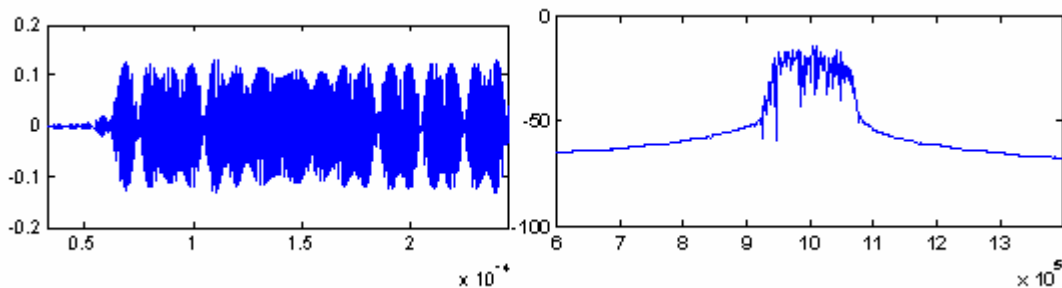

The power of the signal was centered on the carrier frequency. It spans a little bit more than 100 kHz, which is the baseband signal bandwidth. This bandwidth expansion is due to the excess bandwidth of the raise-cosine pulse-shaping filter. The response of the raise-cosine filter used here is shown in the figure below. The 3-dB bandwidth of the filter is 100 KHz, the same as the baseband signal bandwidth. However, the excess bandwidth is about 1.5

times wider than the 3-dB bandwidth. This excess bandwidth will have effect on the design of the multi-sine, as discussed later.

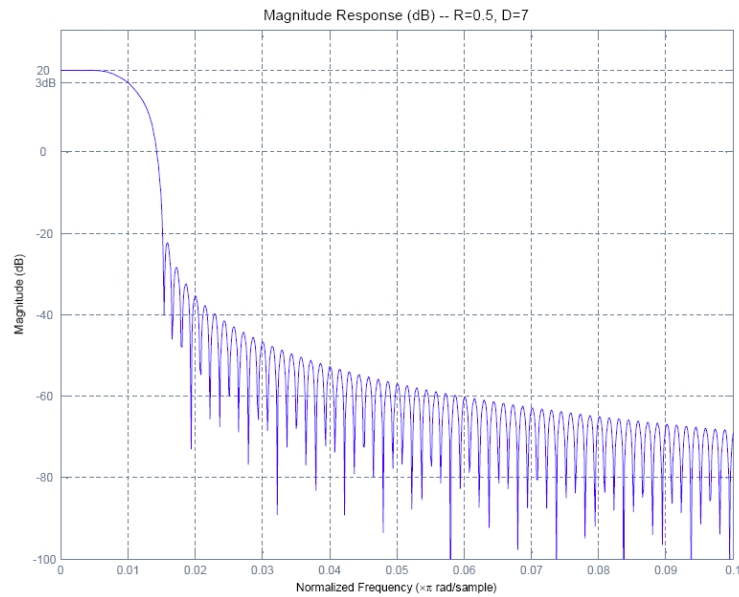

## Implementation of Nonlinear Behavioral Models of an Amplifier

Two behavioral models of an amplifier were implemented in fREEDA (the source files are abmVtanh.h, abmVtanh.cc & abmVcann.h, abmVcann.cc). One is the hyperbolic tangent function. The Tanh function is a convenient nonlinear limiting function that represents the large-signal response of a bipolar or heterojunction bipolar transistor differential pair amplifier

$$v_o = L \tanh\left(\frac{g}{L} v_{in}\right)$$

where  $g$  is the linear gain and  $L$  is the limit value of the output signal.

The second one is the Cann model. It allows independent control of gain, limiting value, and the sharpness of the transition characteristic.

$$v_o = \frac{g v_{in}}{\left[1 + \left(\frac{g}{L} |v_{in}| \right)^s \right]^{\frac{1}{s}}}$$

where  $g$  is the linear gain,  $L$  is the limit value of the output signal, and  $s$  controls the sharpness of the transition from linear to limiting.

The gain compression characteristics of the two models, with parameters  $g=25.68$  dB,  $L=1$ , and  $s=2$ , are shown in the figure below. The 1-dB compression points for the two models occur at the point around -20 dBm input power.

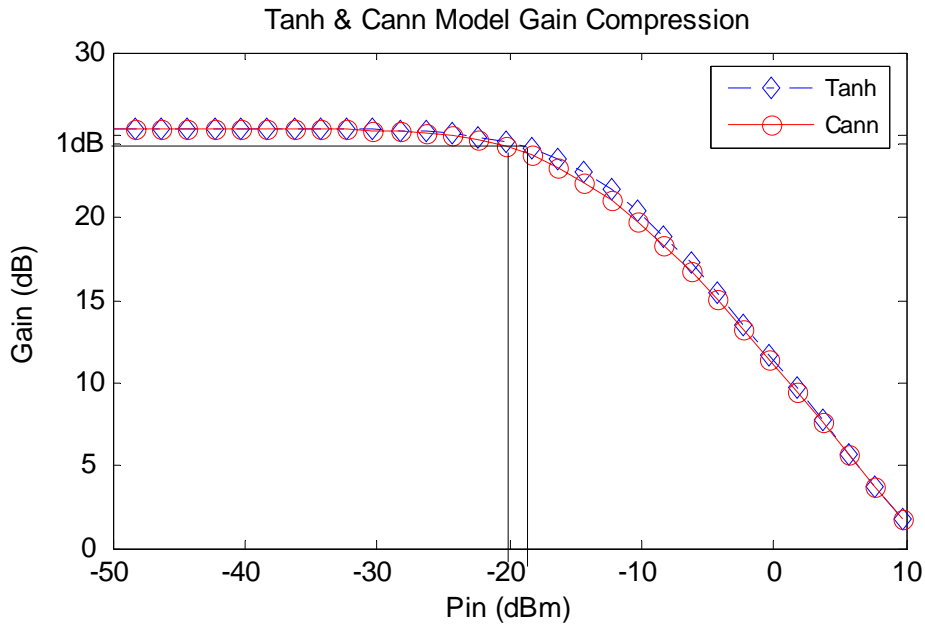

### Design of Multi-Sine Signal

A Fourier transformation based scheme was used to generate a multi-sine signal. Given a digital signal, a realization was taken and Fourier transformation was done on it. As stated earlier in this report, the major portion of power is located in-band centered on the carrier frequency. Therefore, if we truncated the signal with a certain truncation BW without loss of much information in predicting the ACPR, as shown in the figure, then a multi-sine signal can be constructed based on the FT coefficients inside the truncation BW. At each frequency points inside the truncation BW, the magnitude of the sine is obtained by computing the magnitude of the complex FT coefficient, and the phase of the sine is obtained by computing the phase of the complex FT coefficient.

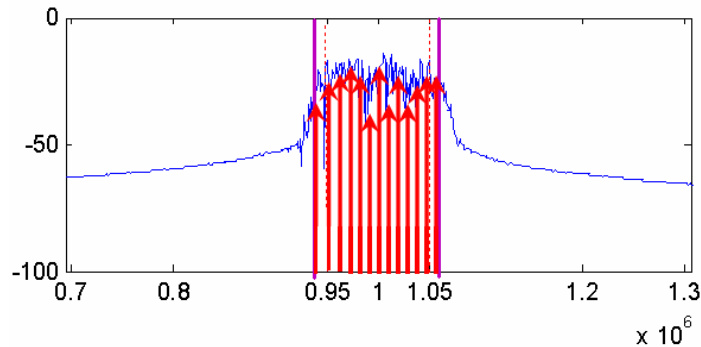

The dependence of the RMS percentage error between the original and the multi-sine signal on the truncation BW was investigated in order to decide the truncation BW.

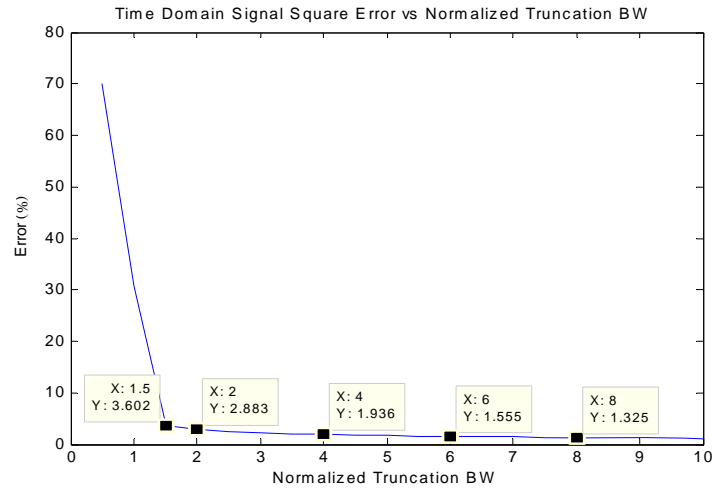

As shown in the figure above, the RMS percentage error decreases with an increase of the truncation BW. In this project, a 1.5x baseband BW was picked to construct a 149-tone multi-sine signal, a realistic number of tones for fREEDA HB simulator. Recalled that the excess bandwidth of the raise-cosine filter is about 1.5x baseband BW too. This makes sense since the major signal power is inside the excess bandwidth of the filter. The RMS percentage error at this truncation BW is about 3.6%.

The comparison of the constructed multi-sine signal and the real QPSK signal are shown in the figure below. The figure on the left shows the time domain waveforms of the two signals, and the one on the right shows the power spectrum of the two signals. The time domain waveforms of the two signals are very similar. The out-of-truncation BW power has been thrown away in the constructed multi-sine signal.

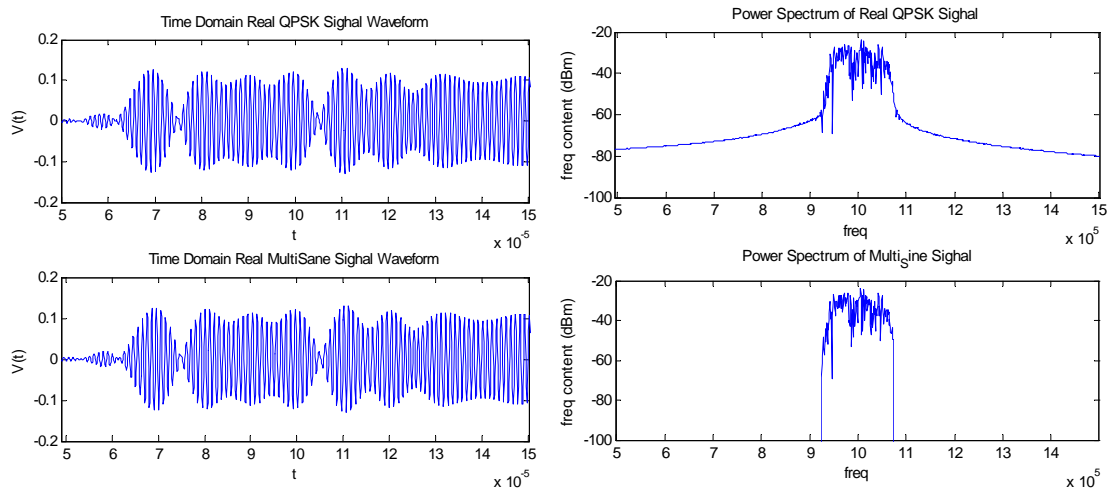

## Simulation Results

The 149-tone voltage source and the nonlinear behavioral model were assembled in two netlist files (tanh\_multisine.net & cann\_multisine.net) for simulation in fREEDA. It takes around 3 hours for fREEDA HB simulator to handle the 149-tone simulation. For comparison, the MatLab and ADS Envelope simulator were also employed for this multi-sine simulation. The results were shown in the table below. The generated multi-sine signal produces very close results compared to the original QPSK signal in predicting the power in the main channel and the ACPR, within 0.1 dB differences. Also, both the fREEDA HB simulator and the ADS envelope simulator give accurate results.

Tanh model, Pin=-10 dBm				Cann model, Pin=-10 dBm			
	Org Signal (MatLab)	Multisine (fREEDA)	Multisine (ADS)		Org Signal (MatLab)	Multisine (fREEDA)	Multisine (ADS)
<b>P<sub>main channel</sub> (dBm)</b>	9.8572	9.8613	9.8612	<b>P<sub>main channel</sub> (dBm)</b>	9.2051	9.2096	9.2092
<b>ACPR<sub>low</sub> (dBc)</b>	-11.7596	-11.8037	-11.8032	<b>ACPR<sub>low</sub> (dBc)</b>	-11.7307	-11.7758	-11.7748
<b>ACPR<sub>high</sub> (dBc)</b>	-11.2955	-11.3178	-11.3184	<b>ACPR<sub>high</sub> (dBc)</b>	-11.2766	-11.2985	-11.3009

The figure below shows the power spectrum of the multi-sine signal (simulated by fREEDA) and the real QPSK signal (simulated by MatLab) after passing through the nonlinear behavioral models. The one on the left is the result of the Tanh model, and the one on the right is the result of the Cann model.

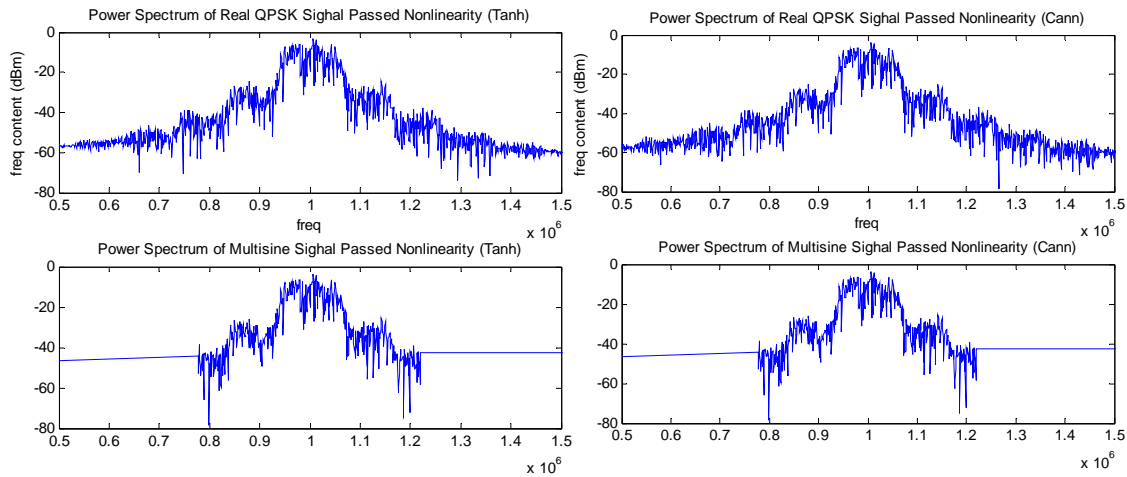

## Conclusions and Future Work

### *Conclusions:*

- Multi-Sine signal is a good approximation of a digital modulated QPSK signal in predicting the ACPR of nonlinear systems.
- Fourier transformation based Multi-Sine signal generation scheme is easy and accurate.
- fREEDA HB simulator is a very powerful and accurate tool in dealing with multi-tone simulation.

### *Future work:*

- Modeling and analysis of more signals, such as 64-QAM, or even some real signals like WCDMA, WLAN signals
- Run test signals on real nonlinear circuits; verify the results with measurement data.
- Look at more figures of merit such as constellation diagram, BER, or EVM.

## References

1. Pedro, J.C.; Carvalho, N.B., "Designing multisine excitations for nonlinear model testing", Microwave Theory and Techniques, IEEE Transactions on, Volume 53, Issue 1, Jan. 2005 Page(s):45 - 54
2. Remley, K.A., "Multisine excitation for ACPR measurements", Microwave Symposium Digest, 2003 IEEE MTT-S International, Volume 3, 8-13 June 2003 Page(s):2141 - 2144 vol.3
3. Gard, K.G.; Larson, L.E.; Steer, M.B., "Statistical analysis of spectral regrowth in wireless nonlinear circuits", Microwave Conference, 2004. 34th European, Volume 2, 13 Oct. 2004 Page(s):697 - 700